

FOUNDATION GROUND PLAN (1:20)

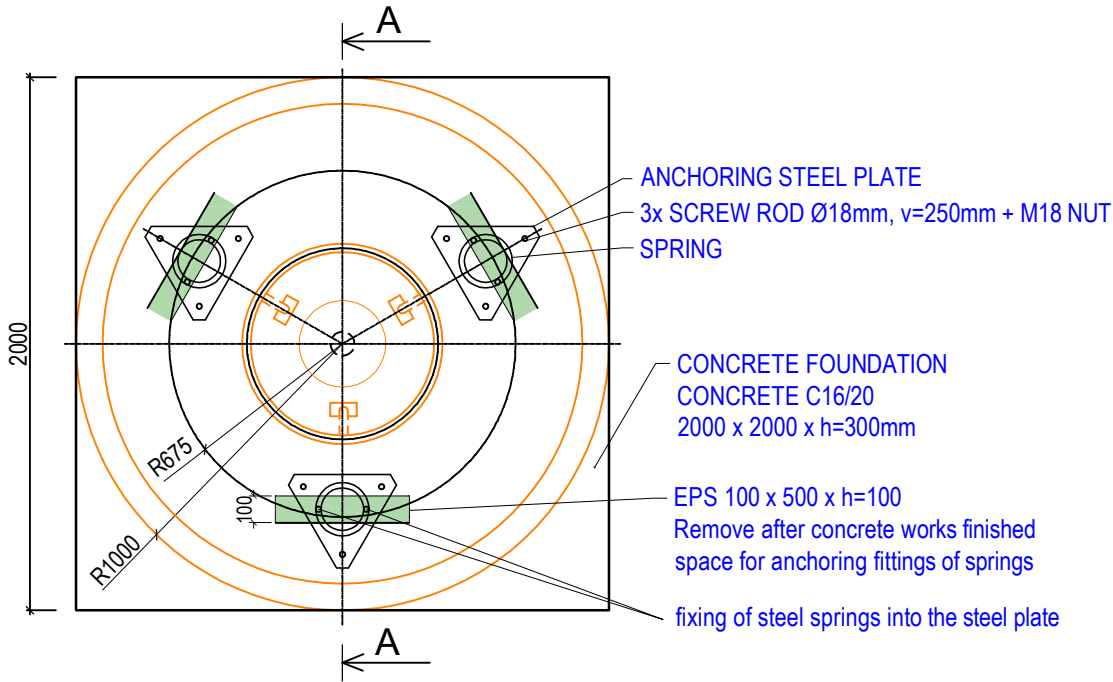

SECTION A-A (1:20)

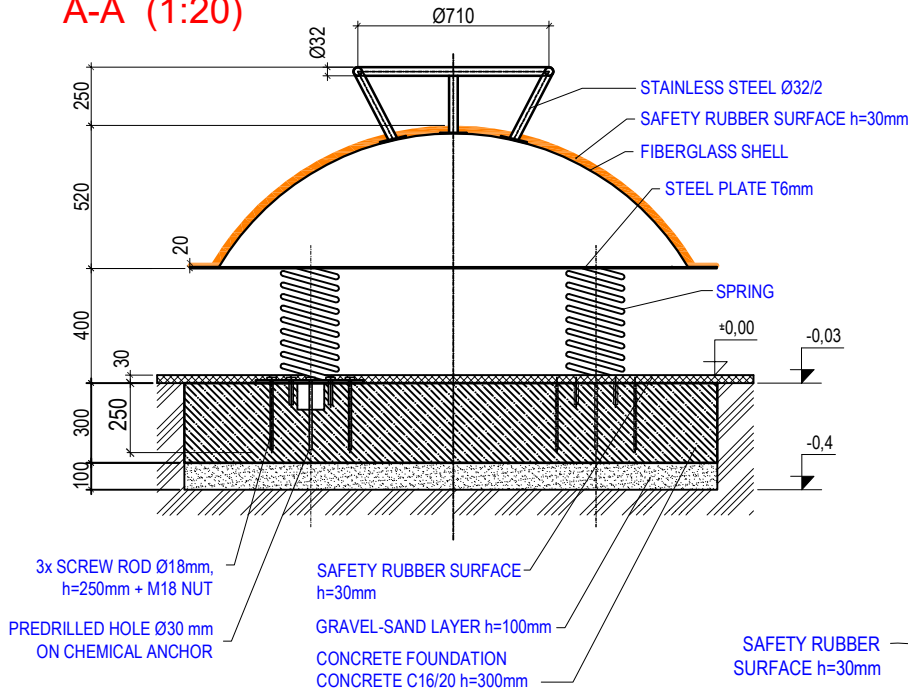

GAPS BETWEEN SPRING COILS MUST BE FITTED WITH SUPPLIED PROTECTIVE INSERT TO ELIMINATE ANY RISK OF FINGER ENTRAPMENT.

ANCHORING DETAIL (1:2)

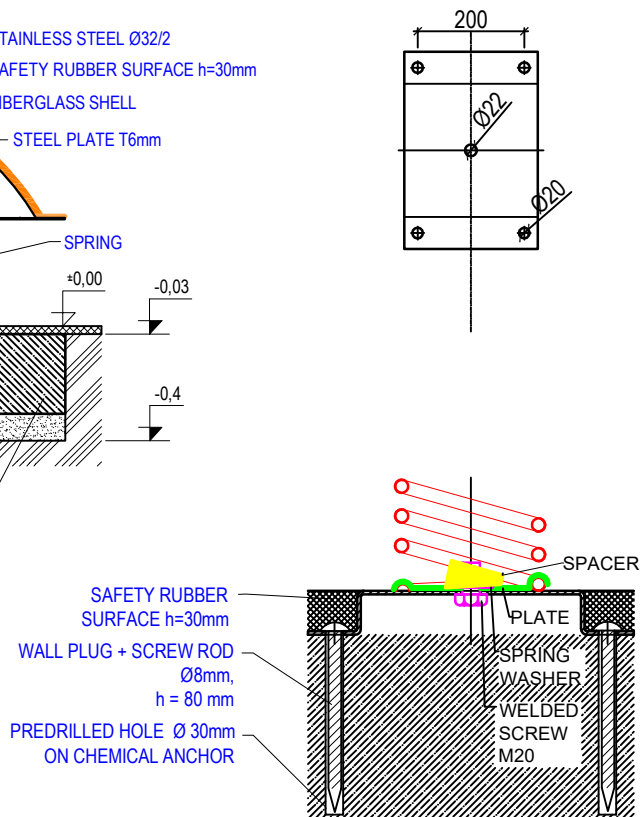

Author:

MgA. Maxmilián Blíšák

3D PROGRAM, s.r.o.

Objizdná 1911
765 02 Otrokovice

Tel: 602 500 045

Email: info@3dprogram.eu



TECHNICAL DRAWING

Certified according to EN71 , EN1176

Date of issue 22.2.2021

E14 - HILL ON SPRINGS

M 1:20, M 1:2

format 1xA4

Foundation and anchoring - ground plan and section

E14_EN.dwg

revision 0